



## Main Features

- 7" VGA TFT LCD monitor
- Automatic/manual brightness control
- Wide range DC input from 9 ~ 36V
- Direct VGA input interface
- Support USB 2.0 and card reader
- Camera sensor on front panel (Optional)
- Optional daylight readable touch support
- Front panel compliant with IP54

## Product Overview

VMD 1001 is a 7-inch TFT LCD monitor with 4 wire resistant touch screen sensor. With the high brightness display and automatically brightness control, it is designed for in-vehicle application. In support of standard VGA interface, it can be configured to link to the most of vehicle computers. It also provides USB and card reader features, and reserves camera sensor as an option. Those friendly interfaces benefit the technicians during maintenances. Its front panel is compliant to IP54, and wide range power input and operating temperature to meet with industrial application.

## Specifications

### General

- Enclosure: Plastic PC + ABS
- Mounting: Support VESA 75, panel and wall mounting
- Power Input: 9 ~ 36VDC
- Power Consumption: 18W
- Ingress Protection: Front panel IP54
- Dimension: 182mm (W) x 138mm (H) x 36.3mm (D)  
(7.17" x 5.43" x 1.43")
- Weight (Net): 0.45Kg, 0.99Lb

### LCD Panel

- 7-inch TFT LCD panel with LED backlight
- 800 x 480 pixels (WVGA)
- Brightness: 500 cd/m<sup>2</sup> (typical)
- Contrast ratio: 600: 1 (typical)

### Touch Screen Sensor

- 4-wire resistant touch
- Anti-glare coatingsurface
- Transmission rate: 82 ± 3%

### I/O Interface-Front

- 5 x Control buttons
  - Power on/off
  - Volume control (+/-)
  - Brightness control (+/-)
- Light sensor
- 2 x LED indicators
- 2 x Built-in speakers (1W)

### I/O Interface-Lateral

- 1 x SD/MMC/MS card reader
- 1 x USB type A for storage
- 1 x Line-in
- 1 x Line-out (automatic detection/switch to external speaker)

### I/O Interface-Bottom

- 1 x Power connector
- 1 x USB type B for touch screen and USB hub
- 1 x VGA

### Optional Features

- 2.0M pixels CCD camera on front panel
- Sunlight-readable touch screen (4 wires resistive w/anti-glare coating)
- Support VESA 75, wall and stand mount kit

### Environment

- Operating temperature: -20°C to 70°C
- Storage temperature: -30°C to 80°C
- Vibration (random): 2.5g@5 ~ 500 Hz
- Vibration
  - Operating: MIL-STD-810G, 514.6 Procedure 1, Category 4, Ground Vehicle – Highway Truck
  - Storage: MIL-STD-810G, 514.6 Procedure 1, Category 4, Integrity Test
- Shock
  - Operating: MIL-STD-810G, Method 516.6, Procedure I, Trucks and semi-trailers=20g
  - Crash hazard: MIL-STD-810G, Method 516.6, Procedure V, Ground equipment=75g

## Dimension Drawing

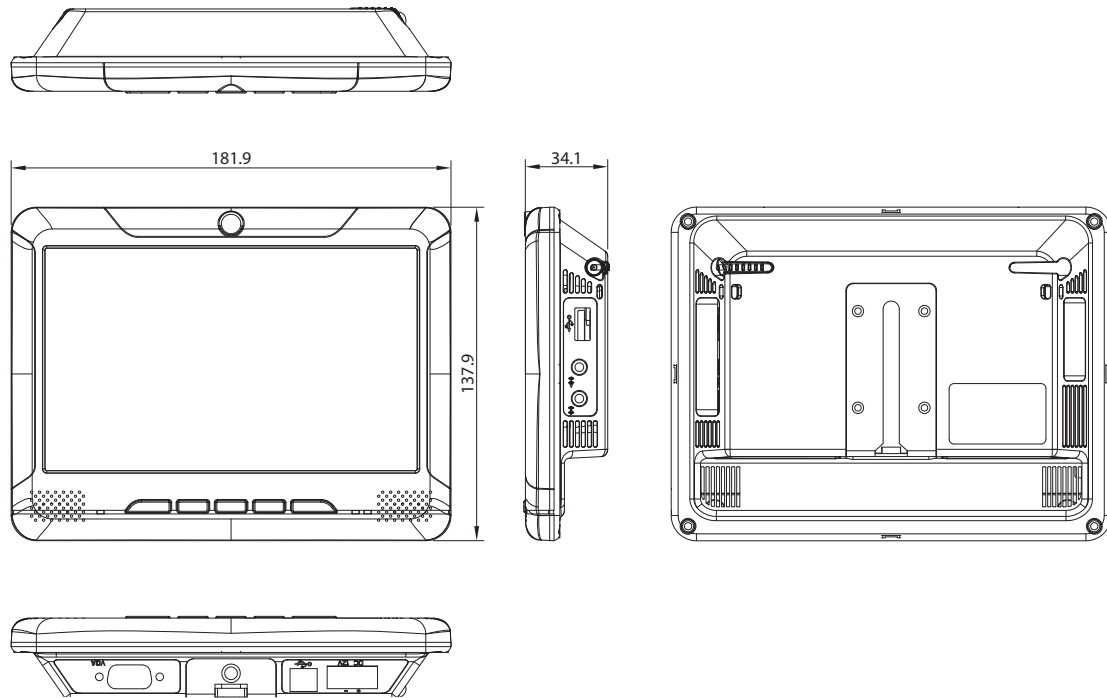

### Standards/Certifications

- ♦ CE approval
- ♦ FCC Class B

### Ordering Information

- ♦ **VMD 1001-B (P/N: 10VD0100101X0)**  
7" VGA vehicle mount display with touch screen and VGA interface
- ♦ **VMD 1001-BS (P/N: 10VD0100102X0)**  
7" VGA vehicle mount display with touch screen, VGA and daylight readable
- ♦ **Bundle Accessories**
  - VGA cable (1.5M)
  - USB cable (1.5M)
  - Metal stand kit
  - Cable fastener
  - Power connector
  - Driver CD