

Industrial 10 ports Gigabit Managed PoE Switch

JetNet 7310G



The JetNet 7310G is an pure Gigabit Managed Switch with 8 ports Gigabit Ethernet plus IEEE 802.3at PoE/PSE function, and 2 Gigabit SFP for Gigabit Ethernet fiber connection.

The Switch system offers 240W system PoE Power budget with 35W forwarding capability in each port with high power input.

The Switch system’s housing is designed with one pieces of heat-sink to dissipate heat when perform high power PoE for DOME IP Camera, Wireless AP. It also provides excellent heat dissipation, even working in road-side cabinet, it still can deliver high power to far-end PoE-PDs. It also adopts comprehensive Layer-3 IP routing feature with brilliant Electro-Magnetic Susceptibility testing level carried out the ability for the Railway Track -Side surveillance.



EN50121-4



Heavy Industrial



Cyber Redundancy



Gigabit



Cyber Security



IEEE1588 PTP

Features

- ▶ 8 Gigabit Ethernet RJ-45 ports ,2 Gigabit Ethernet SFP ports
- ▶ 8 IEEE802.3at PSE with 240W PoE Power forwarding capability
- ▶ Non-Blocking, High Speed Network Switching Fabric
- ▶ Network Redundancy - MSR (Multiple Super Ring),ITU-T G.8032 ERPS, RSTP, MSTP, Super Chain
- ▶ Fully Device Management - SNMP v1/v2c/v3, RMON, Web UI, Telnet and Local Console
- ▶ Friendly Device and Network Topology recovery utility - Korenix View, Korenix NMS
- ▶ Advanced Cyber Network Security -MAC security, IEEE 802.1x Port Based access control , IEEE 802.1x Radius Server authentication, 802.1x MAB, Distributed Denial of Service, IP Source Guard, Denial of ARP Inspection
- ▶ Layer 2 Network Performance - IEEE802.1Q VLAN, Private VLAN, Trunk, Packet Filtering, DHCP Server/Client, Traffic Prioritize, Rate Control
- ▶ Layer 3 Network Routing Protocols - Static/Dynamic Route, VLAN Routing, Multicast Routing
- ▶ Advanced Layer 2 plus packet filtering (ACL) for field site network security
- ▶ Hardware Watchdog for System Auto-Recovery
- ▶ High Level Electromagnetic interference immunity
- ▶ IP Surveillance solution with NEMA-TS2 characteristic
- ▶ Railway Track Side EN50121-4 compliance
- ▶ High Operating Temperature - -40-75°C
- ▶ Redundant wide range power input- DC 46-57V

High Performance Data Acquisition

The Ethernet Switch designed with high Switching Fabric for field data acquisition, and exchange with data center. With the highest Switch Fabric and data stream buffer, the JetNet 7310G approached seamless connective between data center and filed IP surveillance applications. It also provides 9Kbytes packet forwarding ability and excellent H.264 burst stream management technology achieved stable video security through IP surveillance.

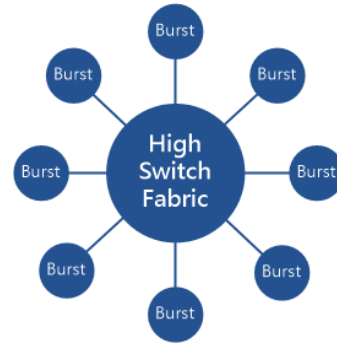

Flexible Uplink Media for Network Architecture Extension

In the metro network architecture, the optical fiber is commonly to use for uplink connection. The JetNet 7310G offers 2 SFP ports with smart fiber transceiver recognize technology approached high quality optical fiber connectivity and enlarge network topology. The Plug and Play characteristics makes user easily change the SFP transceiver for longer communication distance or higher speed connection without any pre-configuration .

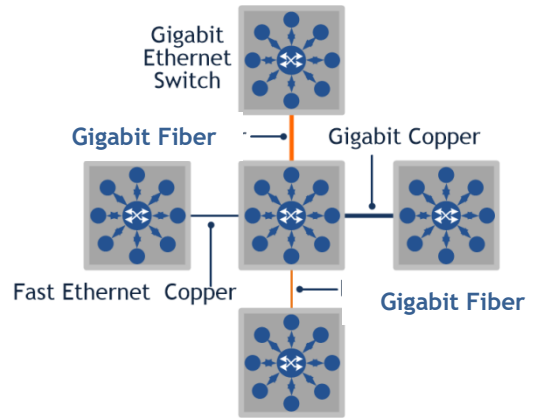

Fiber Optical Quality Monitoring

The fiber optical transmission quality may become unstable, due the moisture, dust or laser diode senile. To reduce the threat of signal broken, the Ethernet Switch provides Digital Diagnostic Monitoring (DDM) to recognize the specification of fiber transceiver. The DDM function enabled user to monitor the launched power, received signal strength, temperature and also alerts user if fiber signal quality getting poor.

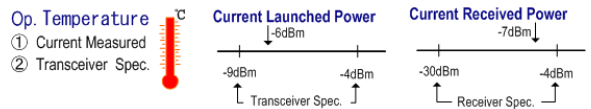

SFP DDM

Port	Remove	Temperature ($^{\circ}\text{C}$)		Tx Power (dBm)		Rx Power (dBm)	
		Current	Range	Current	Range	Current	Range
8	Eject	--	--	--	--	--	--
9	Eject	58.00	0.00 ~ 80.00	-6.0	-9.0 ~ -4.0	-2.0	-30.0 ~ -4.0
10	Eject	62.00	0.00 ~ 80.00	-6.0	-9.0 ~ -4.0	-2.0	-30.0 ~ -4.0

Cyber Network Redundancy

In the Industrial network communication, the reliability of communication always is the critical issue. The 7310G adapts new network redundancy technology - Cyber Network Redundancy includes MSR, Super Chain, ERPS and IEEE standards- RSTP/MSTP technologies to ensure network reliability.

The MSR is a seamless network redundant technology, which includes various technologies for different network redundancy topologies and applications. It includes Rapid Super Ring (RSRTM), Rapid Dual Homing(RDHTM), MultiRingTM and TrunkRingTM. With those network redundant technologies, a node can be configured to multiple rings with failover time less than 50ms, and zero of restoration time.

MSR Multiple Super Ring

Rapid Super Ring

- RM Auto-Select
- Seamless Restoration
- mSec Recovery Time
- Failed Ring Port Together with RM
- Ring Failure LED

MultiRing

- Ring coupling in one unit
- 5 Gigabit Rings

Rapid Dual Homing

- Multiple Uplink Path
- One to One upper
- Many to One upper
- One to Many upper
- Seamless Restoration

TrunkRing

- Active with Port trunk/LACP with MSR, RSR
- Load Balancing
- Auto Backup

Rapid Super Ring (RSR™) Technology

The Rapid Super Ring (RSR™) technology provides advanced Ring Redundancy Technology, its shortest recovery time is from 50ms to few mini second for Fast Ethernet copper/fiber rings, and the Ring-Master (R.M.) can be auto-selected by RSR™ engine. One of Ring path of R.M. is primary path, the other is block path for standby. Once the primary path failed, the 2nd path will be recovered within few mini second. Besides, the restoration time is shortened to zero in R.M. auto-selection mode.

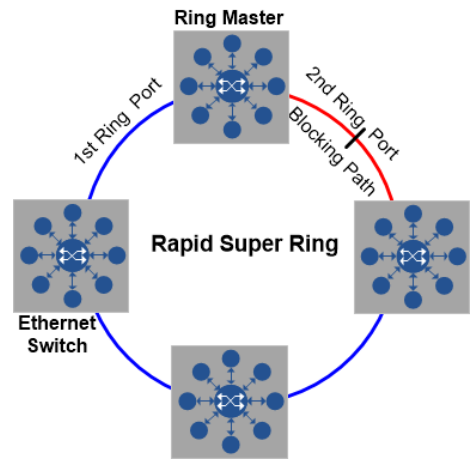

Rapid Dual Homing (RDH™) Technology

The Rapid Dual Homing (RDH™) is designed to engaged Korenix Rapid Super Ring and other vendors Ethernet Switch. It provides easy configuration and multiple redundancies, the failover time is fast than RSTP, and restoration time is zero. Uplinks can be auto detected, and gathered into groups. Each group path are sorted into primary, secondary, and standby. The Link aggregation is also integrated into RDH™. An uplink can be a single or several links as a trunk , which provides better redundancy and capacity.

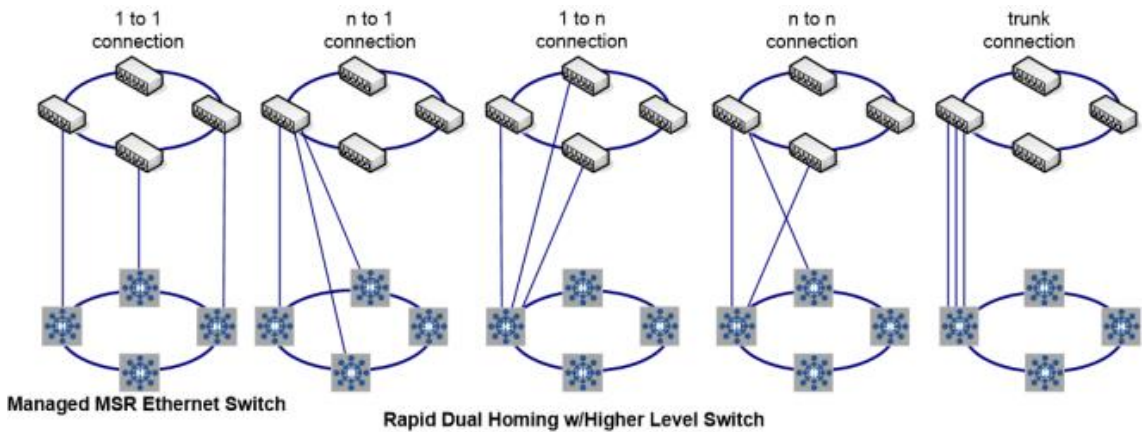

TrunkRing Technology

The TrunkRing is the combination of two technology of RSR and the link aggregation, and takes the advantage of aggregation to increase the path bandwidth. The ring links can be either asymmetric or symmetric. The ring will open only if all the links are broken, and users can enhance the redundancy at different location in accordance to be the need, the path with less bandwidth is more likely to be used as the backup path for restoring the network to full play capacity.

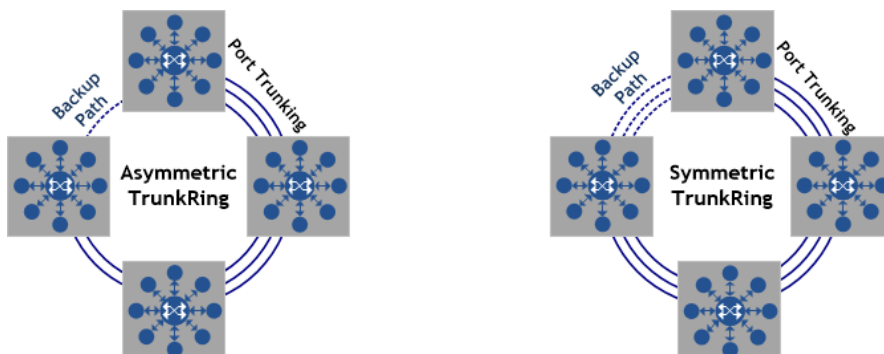

MultiRing Technology

The MultiRing™ provides easier connectivity between two or more ring networks. The simplest sample is to connect two rings by single device. User can extend the network by linking multiple rings into a line or multiple directions. The MultiRing™ has great diversity of various ring technology, when MultiRing™ enabled, the Switch can connect TrunkRing™, RSR™ together and simultaneously provide more high speed ring connectivity. It provides extensibility while keeping the great compatibility.

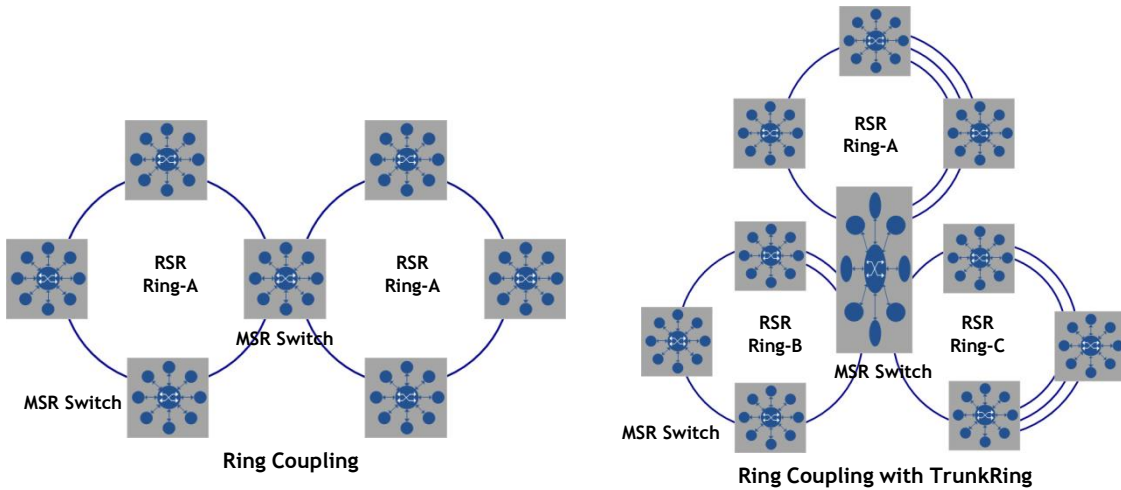

Super Chain Technology

The Super Chain is a new Ring technology that provides a cost-effective way to ring nodes with presented ring to approached flexible, scalability and easy construction. The Super Chain includes 2 borders that connect with other ring by edge port, and the reset nodes are member. Once the ring broken, the standby edge port will backup in few mini seconds, and seamless restoration time when the broken path recovery. Besides, users can add new super ring with existed super ring to approach the flexibility to saving the construction cost.

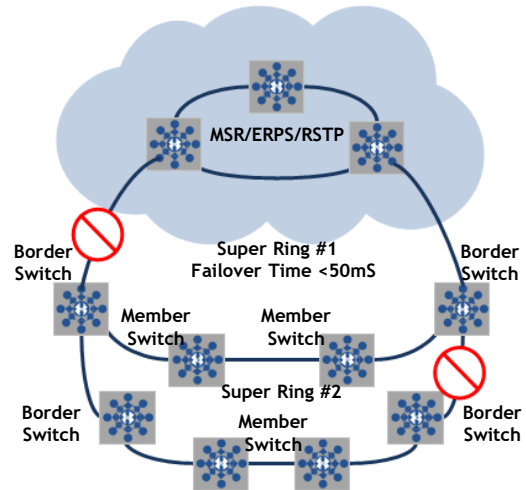

Seamless Ring Port Restoration

Seamless restoration can restore a failed ring without causing any loop problem, topology change and packet loss. With a zero second restoration time, this mechanism eliminates any unstable status and guarantees the applications running non-stop. It ensure MSR™ Ring can harmonic with RSTP protocol. In the figure, the RM will change to another one which nearby the broken path.

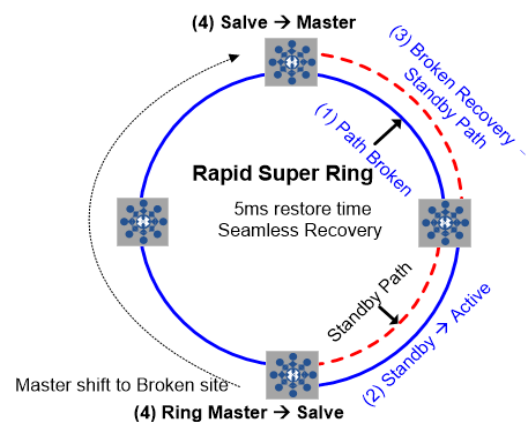

ITU-T G.8032 ERPS

The ITU-T G.8032 Ethernet Ring Protection Switching (ERPS) is a ring technology defined by ITU-T. It includes 2 version ring protocols, ERPS v1 and v2. The v1 supports single ring, and v2 is based on VLAN concept to construct comprehensive ring architecture that engaged several major rings and sub ring. The ERPS protocol is similar as MSR technology with one major host -RPL Owner and several of RPL nodes. The ring restoration and recovery time of ERPS is smaller than 50ms, and slow than MSR. However, the ERPS is an open Ethernet ring redundant protocol that enabled different vendor's ring switch can be integrated together with great network redundancy.

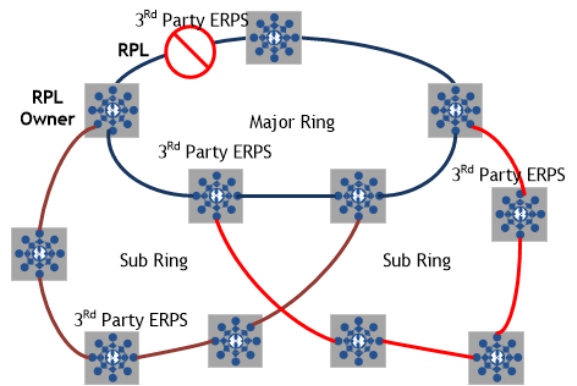

Advanced Cyber Security

The JetNet Switch supports several advanced network security functions to ensure the IT system and data will not get any threat from Cyber network (Internet). The advanced security function includes DHCP Snooping protection, Dynamic ARP inspection (DAI), IP source guard (IPSG), Distribute Denial-of-Service protection and IEEE 802.1x MAB.



DHCP Snooping Protection

The DHCP Snooping is a series of techniques applied to the security of an existing DHCP network. With the DHCP Snooping, the DHCP Server will manage the network access and permit the access with specific IP and specific MAC address from specific Switch port can access the network. It also provides the protection to avoid the intruder added fake DHCP server into a secured network and try to take over DHCP process. Once the Switch detects the phenomena, the port of intruder connected will be lock to protect network access.

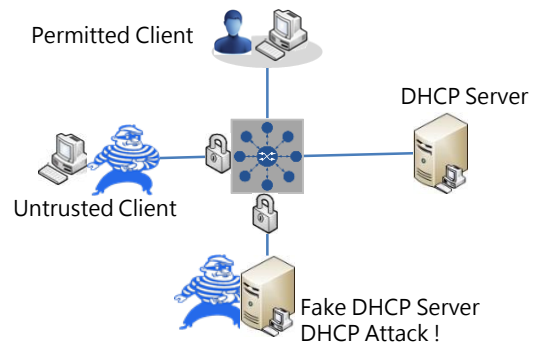

Dynamic ARP inspection Protection

The Dynamic ARP Inspection (DAI) is a security feature that prevents ARP attack. The Switch receives one ARP packet on an untrusted port, the switch compares the IP-to-MAC address binding with entries from the DHCP Snooping database or ARP access-lists. If there is no match, the ARP packet will be dropped by the Switch to ensure network performance.

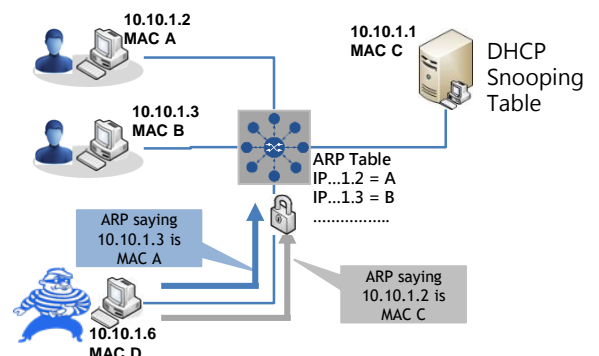

IP Source Guard (IPSG)

IP Source Guard is a security feature that restricts IP traffic on untrusted Switch port by filtering traffic based on the DHCP snooping binding database or manually configured IP source bindings. This feature helps prevent IP spoofing attacks when a host tries to spoof and use the IP address of another host.

Denial of Service (DoS) Prevention

In the internet, a Denial of Service (DoS) or Distributed Denial-of-service (DDoS) attack is an attempt to make a computer or network resource unavailable for intended operating. For the managed Ethernet Switch, the attacker may send lot of service inquire packets to the Switch, and it may caused Switch's CPU get slowly and the network may malfunction. With the DoS protection, the Switch will far way the treat of zombie computer, and keep the network operating as well.

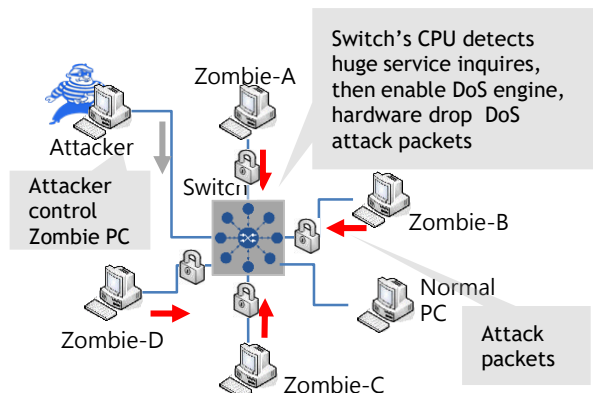
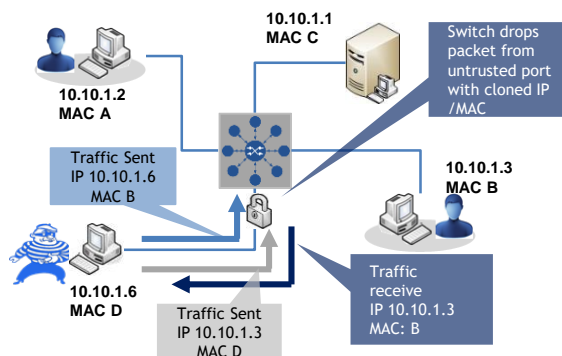

Layer-3 Routing - Accelerates Data Stream in Complex-Network

The Routing is the process of moving packets between different IP address domain or forward to internet. To forward traffic, a router or a Layer-3 Switch need to know the Destination/ Source IP address, the possible and best routes, and verifying /maintain the routing information. The JetNet 7310G offers various of Layer-3 features- Static/ Dynamic routing, VLAN routing, IP Multicasting routing, VRRP and OSPF routing. With those routing function, the Switch can route IP stream in quick and efficiency with high speed scalability, low latency, flow accountable and security as well as.

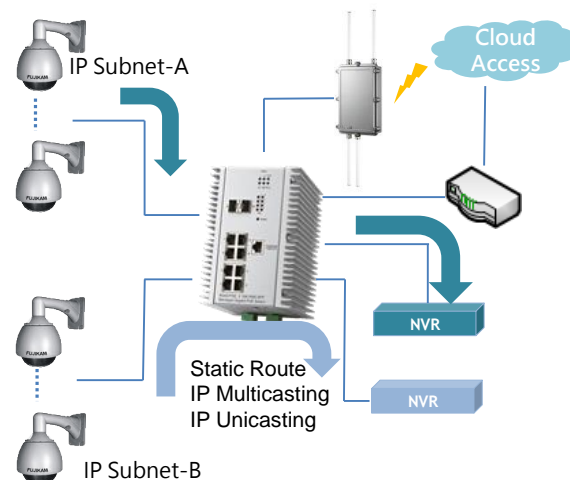

Advanced Layer 2 plus Access Security

In some of industrial automation fields, the advanced network security features are required and must be implemented into field devices. The secured Access Control List (ACL) makes it easy to limit certain communication with other addressed devices by the specific protocol. The ACLs provide "Permit" and "Deny" rules for any or specific host. The Source/Destination MAC address, global IP address or extend IP address with protocol type could be applied as the rules to secure the network from field site access.

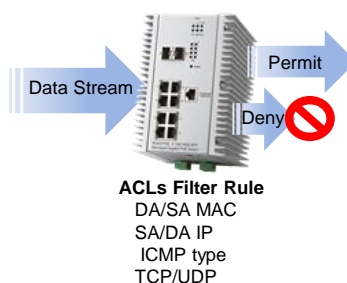

Remote Power Feeding (Power over Ethernet)

The Power over Ethernet technology of JetNet 7310G is compliance with IEEE 802.3at/af standards with 1-event and 2-event behaviors for PD classification. The System maximum power forwarding up to 240W at 75°C operating environment, each PoE port power capability up to 35W. With the high power PoE solution, JetNet Switch can fulfill the demand of High Power Wireless AP, Dom IP Camera with thermal heater.

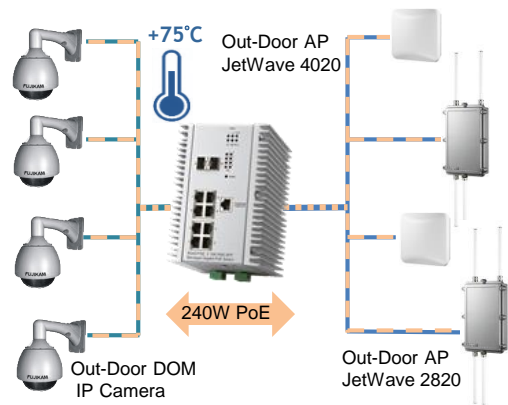

Smart Powered Device Alive Check

The far-end PoE/PD system status can be monitor by enabled the PoE “Link Partner Line Detection” function. Once the PD fails, the connected PoE Switch port will reset the PoE output and bring the PD back to normal working state. This greatly enhance the reliability that PoE/PSE Switch will reset the far-end Powered Device (PD) and reduces your management burden.

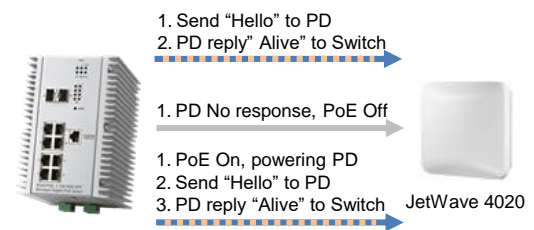

PoE Scheduling Control

The JetNet 7310G provides an scheduling PoE power control mechanism based on hourly/weekly. The PoE port can be configured with different on-off time-slot behaviors by Web user interface, just click and choice PoE-On time-slot and weekly day, then apply the setting to activate it. With the PoE Scheduling Control feature, the JetNet 7310G can meets economical power management, power saving, security or customer-specific requirements.

Power over Ethernet Schedule

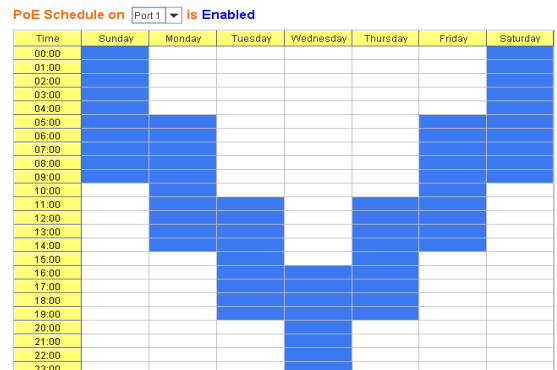

Survival in Hash Environment

The technology of PoE are commonly deployed in smart city applications, like as public facility IP surveillance, free Internet Wireless Access. Therefore, the Switch may located at hash environment with extreme temperature and interference of electric noise. As this resulting, the JetNet 7310G adopts excellent heat dissipation design to operating in -40-75C environment , and also supports high grade EMC protection to bear those out-door applications.

Condition	Performance
Temperature	-40-75°C, 240W PoE
ESD Contact/Air	6KV/8KV, Criteria A Level-3 Testing Severity
Surge /Lighting Attack	2KV at Power, Ethernet Level-3 Testing Severity
Electric Transient	2KV at Power, Ethernet Level-3 Testing Severity

Specification

Technology	
Standard	IEEE 802.3u 100 Base-TX Fast Ethernet IEEE 802.3ab 1000 Base-T IEEE 802.3z Gigabit Ethernet Fiber IEEE 802.3x Flow Control and Back-pressure IEEE 802.1AB Link Layer Discovery Protocol (LLDP) IEEE 802.1p Class of Service (CoS) IEEE 802.1Q VLAN and GVRP IEEE 802.1D-2004 Rapid Spanning Tree Protocol (RSTP) IEEE 802.1s Multiple Spanning Tree Protocol (MSTP) IEEE 802.3ad Link Aggregation Protocol (LACP) IEEE 802.1x Port Based Network Access Protocol IEEE 802.3af/at Power over Ethernet
Performance	
Switch Technology	Store and Forward Technology with Non-Blocking 20Gbps Switch Fabric
CPU performance	32 bits CPU with Hardware based Watch-dog timer with 10S reset timer
System Memory	32MBytes flash ROM, 256M bytes system RAM
Transfer packet size	64 bytes to 9K bytes Jumbo Frame
MAC Address Table	16K
Packet Buffer	1.5MBytes shared memory for packet buffer with intelligent memory management unit for burst data traffic
Transfer performance	14,880pps for Ethernet and 148,800 for Fast Ethernet, 1488,100 for Gigabit Ethernet
Management	
Management Interface	Telnet with SSH, Web Browser with SSL, SNMP V1/V2c/V3 with SNMP Trap (up to 4 trap stations), RMON (Group 1,2,3,9) for in-band management. Local RS-232 connector for out-band management.
Management Security	The maximum management session up to four, and support management Host IP secure feature to prevent unauthorized remote login
SNMP MIB	MIB-II, Bridge MIB, Ethernet-like-MIB, VLAN MIB, IGMP MIB, Private MIB
NMS	Windows based NMS (Network Management System) -Korenix NMS and Korenix View for device discovery and topology map auto construct
Network Time Protocol	NTP with daylight saving and localize time sync function
Management IP Security	Predefined Host IP address for management host login security
E-mail Warning	4 Receipt E-mail accounts with E-mail server authentication
System Event Log	2 Event log record modes- Local and remote Log Server with authentication
Network Performance	
Port Configuration	Port link Speed, Link mode, current status and enable/disable
Port Trunk	IEEE 802.3ad Link Aggregation Control Protocol (LACP) and Static port trunk; trunk member up to 8 ports in one group, maximum 5 trunk groups
VLAN	IEEE 802.1Q Tag VLAN with 256 VLAN Entries and provides 2K GVRP entries; 3 VLAN link modes- Trunk mode, Hybrid mode and Link access mode
Private VLAN	The Private VLAN is special for group uplink access with independent port security. With the private VLAN function, each VLAN community is isolated and only exchange by high level device with primary VLAN community
IEEE 802.1Q QinQ	Supports Double VLAN tag for VLAN isolation and security
IEEE 802.1p	The Ethernet Switch MAC controller supports IEEE 802.1p Class of Service function; Per interface with 4 queues
IGMP Snooping	IGMP Snooping v1/v2/v3 for multicast filtering and IGMP Query mode; also support unknown multicasting process forwarding policies- drop, flooding and forward to router port
Rate Control	Ingress/Egress filtering for broadcast, multicast, unknown DA or all packets

Port Mirroring	On-line traffic monitoring on multiple selected ports
DHCP	System supports DHCP Client function for dynamic IP address obtain from DHCP Server, and the Switch also support DHCP Server function with DHCP Relay Agent to forward DHCP request through specified forwarding path. The DHCP Server also offer port based DHCP Server function with predefined IP address or perform MAC&IP address binding function
IEEE 802.1x/ Port Security	Port based network access control, and authenticated by localize pre-defined MAC address or remote RADIUS Server
Power over Ethernet	IEEE 802.3af, IEEE 802.3at, End-Span wiring architecture
PoE operating mode	Auto Mode: IEEE 802.3af/at behaviors with IEEE802.3af 1-Event and IEEE 802.3at 2-Event classification for standard PD Forced Mode: User configured Power consumption budget control with IEEE 802.3 PoE /PD detection, or forced without PD detection
PoE forwarding conductor	RJ-45: V+(3,6), V- (1,2)
Power forwarding capability	PoE Port: 15W/IEEE 802.3af, 30W/IEEE 802.3at, 35W /IEEE 802.3at with high power voltage input PoE System Power Budget: 240W at 75°C Ambient temperature
PoE System Power Budget	Power Budget Reserve by PD declaration. The power budget control system will reserve power for connected PD device, once latest PD device (PoE 8) claimed power over the system surplus power, then the latest PoE will be disabled System Power Budget: 240Watts / 54V for High Power PoE Input Voltage
Network Redundancy	
Multiple Super Ring (MSR™)	New generation Korenix Ring Redundancy Technology, Includes Rapid Super Ring, Rapid Dual Homing, TrunkRing™, MultiRing™, Super Chain™ and backward compatible with Legacy Super Ring™
Rapid Dual Homing (RDH™)	Multiple uplink paths to one or multiple upper Switch, up to 256 Groups RDH™ Peer protection
TrunkRing™	Integrate port aggregate function in ring path to get higher throughput ring architecture
MultiRing™	Supports redundant ring up to 5 Gigabit rings in one device
Super Chain	It is new ring technology with flexible and scalability, compatibility, and easy configurable. The ring includes 2 types of node Switch - Border Switch and Member Switch
Rapid Spanning Tree	IEEE 802.1D-2004 Rapid Spanning Tree Protocol; it compatible with Legacy Spanning Tree and IEEE 802.1w
Multiple Spanning Tree	IEEE 802.1s Multiple Spanning Tree, each MSTP instance can include one or more VLANs, and also supports multiple RSTP deployed in a VLAN or multiple VLANs
ITU-T G.8032 ERPS * Note-1	Support ITU-T G.8032 ERPS V1 single ring topology, and ERPS v2 multiple rings with ladder topology
Cyber Security *Note-2	The Cyber Security function includes- DHCP Snooping protection, Dynamic ARP inspect protection, IP Source Guard (IPSG), Distribute Denial-of-Service (DDoS), IEEE 802.1x MAB for non-IEEE 802.1x compliant device.
Industrial Protocol	Modbus/TCP, Ethernet/IP
Routing Protocols	
IP Routing	Supports Default Static and Dynamic Route
Virtual LAN Routing	Incorporate both of IEEE802.1Q Bridge and Routing Function
Routing Information Protocol	Hop-Based IP Routing with RIPv1 and RIPv2
IGMP	Multicast Group Management Protocol support IGMP v1,v2
Multicast Routing	128 IP Multicast Routing entries
VRRP	Short of Virtual Route Redundancy Protocol, Automatically Backup Routing route to specified router
OSPF	Link State based IP routing protocol support OSPFv1 and OSPFv2

Interface	
Enclosure port	<p>1000Mbps Gigabit Ethernet port (#1-#8): 8 x RJ-45 Connectors with IEEE 802.3at PSE function</p> <p>SFP port (#9,#10): supports 1000Mbps Fiber Transceiver with Digital Diagnostic Monitoring (DDM) for optical fiber quality inspection. The SFP connection with high priority than RJ-45 copper.</p> <p>Power input: 4-Pin Removable Terminal Block Connector</p> <p>Digital Input: Semi Digital Input (Low: 0-10V, High:11-30V)</p> <p>Digital Output: Dry Relay Output with Normal Open operating mode with DC 24V/0.5A contact capability</p>
Reset Button	System hardware reset
Cables	<p>100Base-TX: 2 pairs STP Cat.5e/Cat.6 cable, EIA/TIA-568B 100-ohm (length:100Meters)</p> <p>1000Base-T: 4 pairs STP Cat. 5e/Cat.6 cable, EIA/TIA-568B 100-ohm (length:100Meters)</p> <p>Power Cable: Recommended uses 18AWG electrical power cable with UL certification for the high power PoE application</p>
Diagnostic LEDs	<p>1000Mbps RJ-45 port: Link (Green on)/Activity (Green Blinking),Speed 1000 (Amber on) PoE: PoE forwarding (Amber on), PoE abnormal or detection (Blinking)</p> <p>1000Mps SFP: Link/Activity (Green on, Green Blinking), Speed 1000 (Amber on)</p> <p>Power: Power on (Green on)</p> <p>Alm: Alarm(Red on)</p> <p>Sys: Ready (Green on)</p> <p>R.S: Green on (Ring Normal)/Blinking (wrong ring port connective), Amber on (Ring abnormal)/Blinking (ring port failed)</p> <p>D.I.: Digital Input (Green on)</p> <p>D.O.: Dry Relay Output (Red on)</p>
Power Requirements	
System Power Input	<p>IEEE 802.3at 30W PoE application: DC 50-57V</p> <p>IEEE 802.3af 15.4W PoE application: DC 46-57V</p>
Power Consumption	<p>DC 48V: 14.5W (without PoE loading)</p> <p>DC 53V: 15 W (without PoE loading)</p> <p>DC 57V: 15.4W (without PoE loading)</p>
Mechanical	
Installation	EN50022 DIN Rail Mount
Dimensions	<p>108mm (W) x 160mm (H) x 136mm (D)-with mounting ears</p> <p>108mm (W) x 160mm (H) x 127mm (D)-without mounting ears</p>
Material Housing	Steel Metal with Aluminum Housing
Ingress Protection	IP-31
Environmental	
Operating temperature	-40-75°C: 240Watts with PoE full loading
Operating humidity	0%-95%, non-condensing
Storage Temperature	40-85°C
Hi-Pot	<p>Power- Chassis GND/Housing: AC 1.2KV/ DC 2.25KV</p> <p>RJ-45 - Chassis GND/Housing: AC 1.2KV/ DC 2.25KV</p>
Regulatory Approvals	
Railway Application	Rolling Stock Track Side EN50121-4
EMC	<p>EMI: IEC/EN61000-6-2, Compliance with EN50121-1/-4 , CE class A, FCC sub part-15 class-A</p> <p>EMS: IEC/EN61000-6-4, Compliance with EN50121-1/-4, EN61000-4-2/-4-3/-4-4/-4-5/-4-6/-4-8/-4-9</p>
Vibration & Shock	Compliance with IEC 61373

* Note-1: ITU-T ERPS V2 (By Request)

* Note-2: Cyber Security (By Request)

Dimension (Unit = mm)

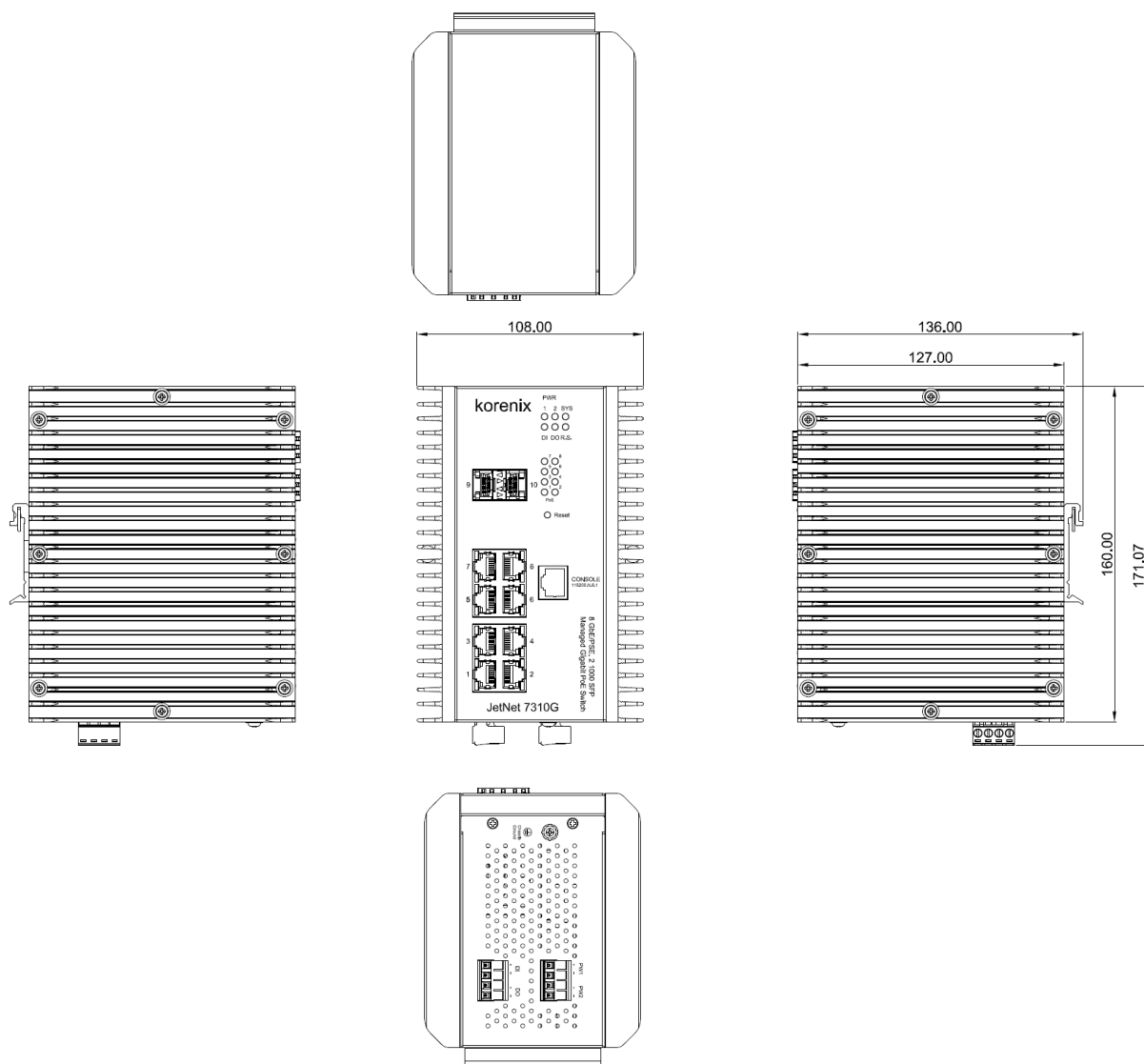

Ordering Information

JetNet 7310G Industrial 10 ports Gigabit Managed PoE Switch, 240W PoE, -40~75°C

Each Unit include:

- ▶ JetNet 7310G x1
- ▶ Quick Installation Guide
- ▶ DIN Rail Mounting kit

Optional Accessories

Mounting Kit

MTK-W-143 Mounting Kit, Wall-mount plate, 143x38mm

MTK-RD-130 Mounting Kit, Robust DIN rail adapter, 130x52mm