

# Winmate E-Series HMI

15" E-Series HMI with Freescale i.MX6

R15FA3S-EHC3

- 15" 1024 x 768 Resolution with Projected Capacitive Multi-Touch (P-CAP)
- Freescale Cortex A9 i.MX6 Dual Core 1GHz
- Fanless cooling system and Ultra-low power consumption
- Support PoE function
- Front IP65 Water and Dust Proof
- 1 x USB ; 1 x RS232 / 422 / 485 ; 1 x CAN BUS ; 1 x Micro SD Slot

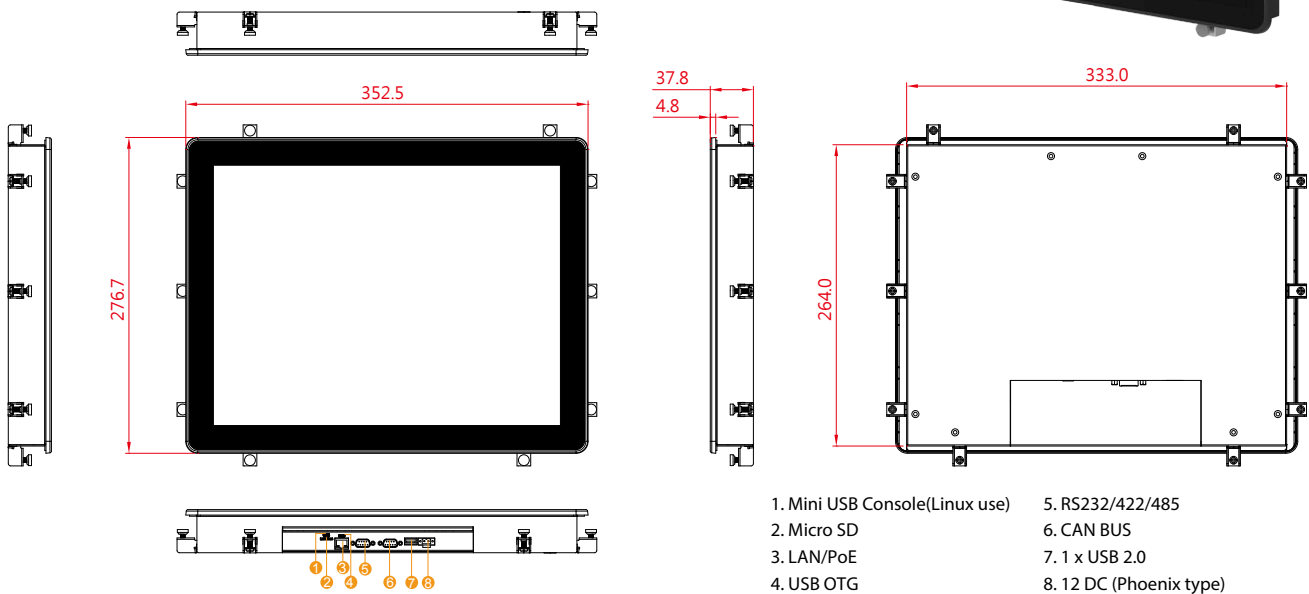

1. Mini USB Console(Linux use)
2. Micro SD
3. LAN/PoE
4. USB OTG
5. RS232/422/485
6. CAN BUS
7. 1 x USB 2.0
8. 12 DC (Phoenix type)

## Specifications

### System :

- Processor : Freescale Cortex A9 i.MX6 Dual Core 1GHz
- System Memory : 1GB LPDDR3
- Storage : Onboard 16GB eMMC / Micro SD card

### Input / Output :

- USB Ports : 1 x USB 2.0 host, 1 x USB OTG
- COM port : 1 x RS232 (Optional 422/485)
- CANBUS : 1 x CANBUS
- Ethernet : 1 x RJ45, 10/100/1000 LAN Support PoE function
- SD Slot : 1 x Micro SD Card Slot
- Debug : 1 x Mini USB to Debug

### Power Specifications :

- Power Input : 12V DC
- Power Over Ethernet: Support PoE (optional), Power Device (PD): follows IEEE 802.3at (25 W)  
\* Recommended to use without other power-consuming devices
- Power Consumption : 13W(typ.)

### Display Spec :

- Size/Type : 15"
- Resolutions : 1024 x 768
- Brightness : 300 nits
- Contrast Ratio : 700:1 (typ.)
- Viewing Angle : -80~80(H); -80~80(V)
- Max Colors : 16.7M (8bit)
- Touch : Projected Capacitive Multi-Touch (P-CAP)

### Mechanical Specification :

- Cooling System : Fanless design
- Mounting : Mounting clips x 8
- Dimension (W x H x D) : 276.7 x 352.5 x 56.3
- Cutout Dimensions (W x D) : 390.4 x 227.3 (mm)
- Design : Panel Mount Front IP65 Design

### Environment Considerations :

- Operating Temperature : -10 deg.C to 50 deg.C
- Operating Humidity : 10% to 90% (non condensing)

### OS/BSP Driver Support :

- Operation System : Android 6.0 (Default)  
: Ubuntu 16.04 (Optional)  
: Linux Kernel 4.1.15, QT 5.5 Browser (Optional)

