

- Industrial Fanless Panel PC in stainless steel 316L cased
- Display LCD TFT 19" - LED backlight
- Resolution XGA 1024 x 768
- Available with resistive touch screen
- IP66 six sides
- CPU Intel® Atom™ Core Quad E3845 1.9GHz
- Use your standard cables
- Internal industrial power supply
- VESA 100 compatible



316L stainless steel IP66 six sides



Wifi internal with rugged antenna



I/O trap protection with cable gland

I/O ports

- | | |
|------------------|---------------|
| 1 - Power | 12 - Line out |
| 2 - USB 2.0 | |
| 3 - COM 2 | |
| 4 - USB 2.0 | |
| 5 - USB 3.0 | |
| 6 - Ethernet 2 | |
| 7 - Ethernet 1 | |
| 8 - Display port | |
| 9 - COM 1 | |
| 10 - Micro | |
| 11 - Line in | |

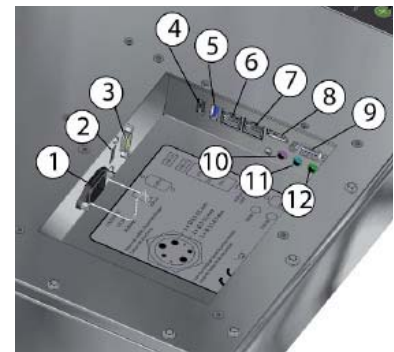

Mechanical Drawing

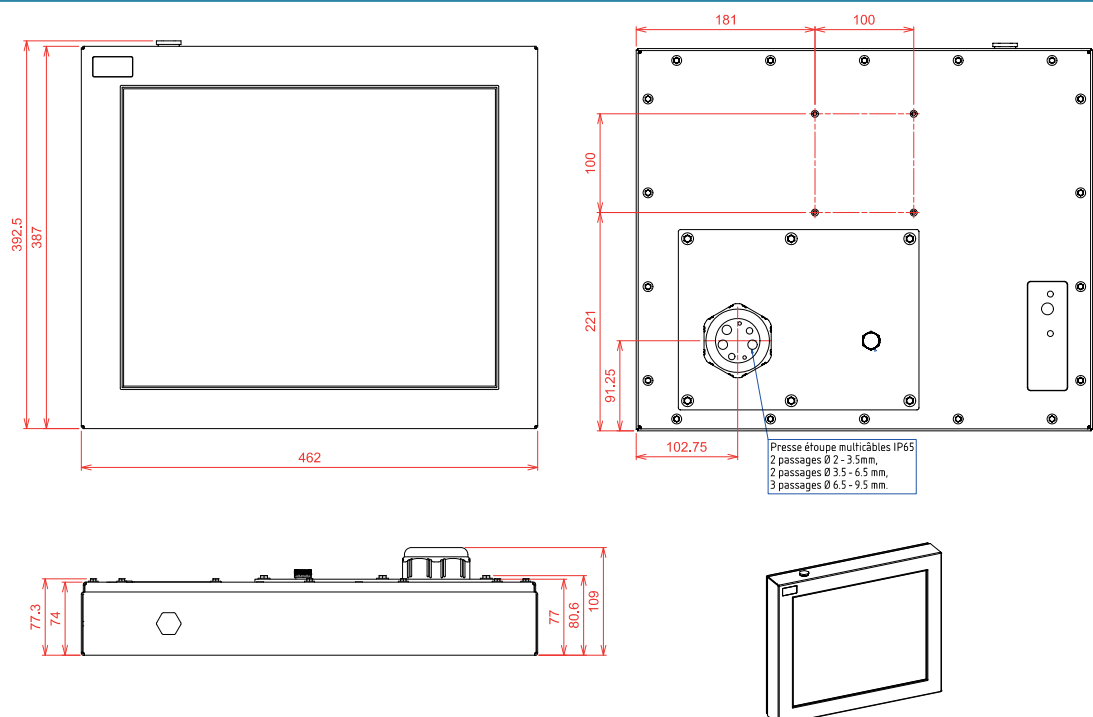

Specifications

Chassis	Construction	1.5 mm thick 316L stainless steel with treatment S4
	Without touch screen	Tempered and anti-reflection Glass
	Mounting	VESA 100 compatible Stainless steel mounting solution: Table stand - wallmount - ...
Display	Protection	IP66 six sides
	LCD Size	19" - LED Backlight
	Active area	376 x 301 mm
	Resolution	1280 x 1024 SXGA
	LCD Color	16.7 millions
	Pixel Pitch	0.294 mm
	Brightness	250 cd/m ²
	Contrast Ratio	1000 : 1
Touch Screen	Viewing Angle	H: 170° - V: 170°
	Technology	Resistive type (5-wire)
CPU	CPU	Intel® Atom™ E3845 1.91GHz
	Chipset	Intel® Atom™ SoC
	RAM	2x DDR3L SO-DIMM (max. 8.0 Go)
Operating System		Windows 7 / 8.1 - Linux on specification
Drive bay	HDD / SSD	1 x 2" 1/2 SATA
I/O port under cover cable gland		1 x USB 3.0 - 2 x USB 2.0 - 2 x RS-232 - 1 x Display port
		2 x GigabitLan (RJ45) - 1 x Audio
		Passage: 3 x Ø 6.5 – 9.5 mm - for power cord
		Passage: 2 x Ø 3.5 – 6.5 mm Passage: 2 x Ø 2 – 3.5 mm
Button & Indicator	Rear panel	ATX On/Off switch button - Reset button Power Led - HDD activity Led Brightness control keypad
System Cooling		Fanless
Dimensions	Dimension WxHxD (mm)	462 x 392.5 x 109
	Weight (kg)	11
Industrial Power Supply	VAC~	Input: 90-264VAC - Frequency: 47/63Hz Power consumption: 50 W max.
Safety & EMC	Security	EN60950-1
	EMC	EN55022, EN61000-3-2, EN61000-3-3, EN55024, EN-61000-4-2, EN-61000-4-3, EN-61000-4-4, EN-61000-4-5, EN-61000-4-6, EN-61000-4-8, EN-61000-4-11
Environment	Operating Temperature	0° ~ + 40°C
	Storage Temperature	- 20 + 60°C
	Relative Humidity	5 95 %
Warranty		2 years Parts & Labour return to base as standard
Options & Accessories	RT (in end of items)	Resistive Touch screen
	OPT/ETHRABGN/ODY19	Internal Wifi solution 802.11 a/b/g/n - Rugged antenna
	OPT/BTH/USB/NMO/ODY	Internal bluetooth solution
	X/SUPPORTMUR/VIK	Wallmount support in 316L stainless steel
	OPT/PIEDTABLE/INOX	VESA 75/100 stand table support in 316L stainless steel



Stand mount support in 316L stainless steel



Wallmount support in 316L stainless steel



Head tube support in 316L stainless steel



Plug box IP66 in 316L stainless steel

Ordering Information

ODYSEE19QA/AC

Industrial fanless Panel PC in stainless steel 316L chassis - IP66 six sides - LCD TFT 19" LED - Intel® Atom™ CQ E3845 - 230VAC

ODYSEE19QART/AC

Industrial fanless Panel PC in stainless steel 316L chassis - IP66 six sides - LCD TFT 19" LED - Intel® Atom™ CQ E3845 - Resistive touch screen - 230VAC

Please ask for additional information about **Options & Accessories**.

Packing list

- 1 Power cord CE22 1.80 m (AC~ version)
- 1 Utility CD includes: User's manual
- 1 Utility CD includes: Drivers
- 1 Software Licence (label format)
- 1 Production&Traceability datasheet